

Articolazioni angolari con testa sferica temprata

Ball joints rod ends with shank

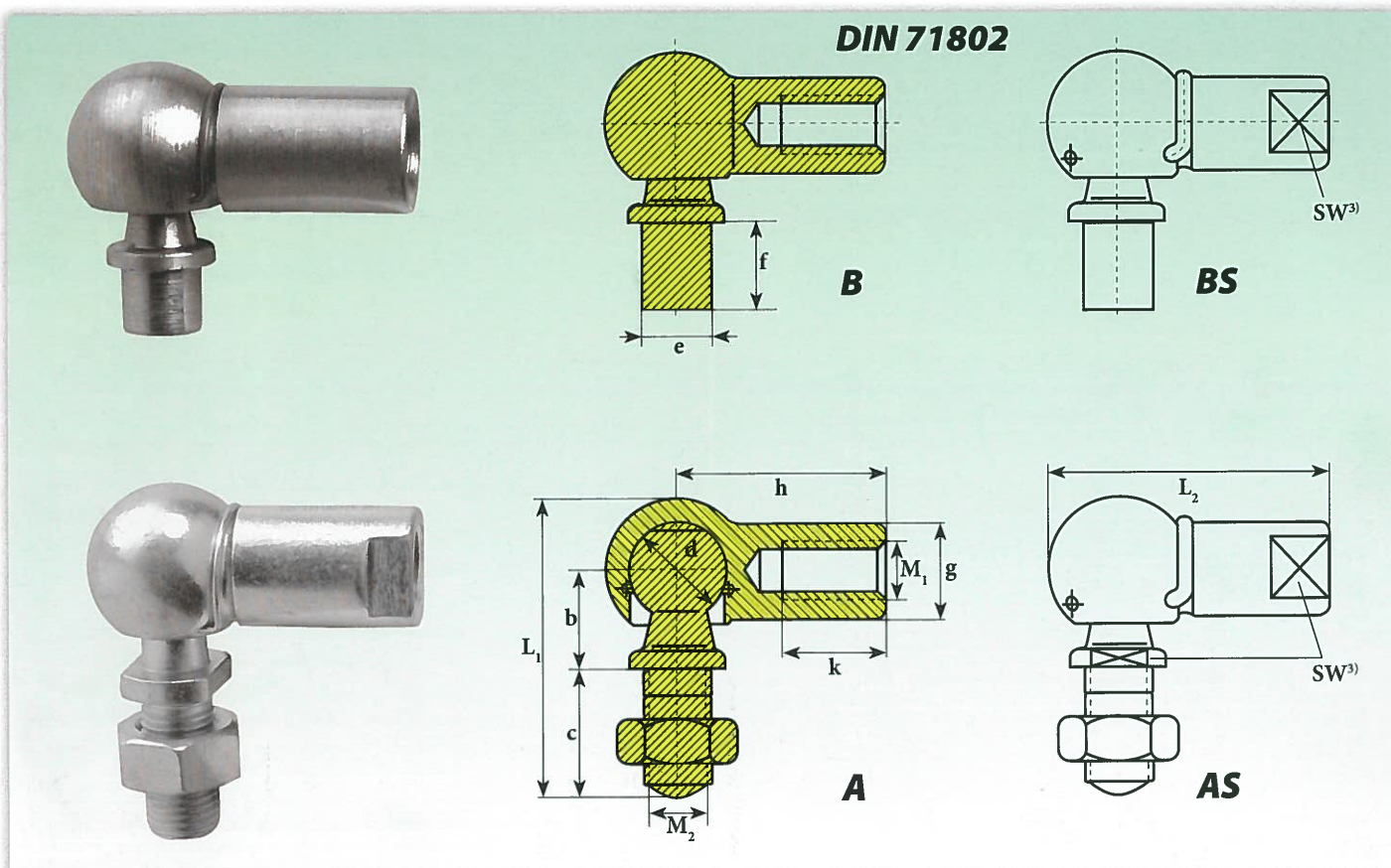

Sigla ¹⁾ Designation ¹⁾		Dimensioni mm Dimensions mm													Peso Weight B-BS	Peso Weight A-AS
con tenuta a molla ²⁾ with spring clamping ²⁾	con anello di sicurezza with safety ring	d H9/h8	b _{±0,3}	c _{±0,3}	e _{h11}	f _{±0,2}	g	h _{±0,3}	k _{min}	L ₁	L ₂	M _{1 (6H)} - M _{2 (6g)}	SW ³⁾ _{h14}	≈ Kg	≈ Kg	
B - BS 8	A - AS 8	8	11	12,5	5	4	7,5	8	24,5	12	31	32	M 5x0,8	8	0,013	0,014
B - BS 10	A - AS 10	10	11	12,5	6	4,5	8	10	24,5	12	31	32	M 6x1	8	0,021	0,024
B - BS 13	A - AS 13	13	13	16,5	8	5	8	10	29,5	14	40	39	M 8x1,25	11	0,044	0,053
B - BS 16	A - AS 16	16	17	20	10	6	10	13	34	18	49	46	M 10x1,5	13	0,084	0,097
B - BS 16-1	A - AS 16-1	16	17	20	10	6	13	16	34	18	49	46	M 10x1,75	13	0,084	0,097
B - BS 19	A - AS 19	19	23	28	14	12	18	22	45	22	66	60	M 14x2	17	0,184	0,218
B - BS 19-1	A - AS 19-1	19	23	28	14	12	18	22	45	22	66	60	M 14x1,5	17	0,184	0,218

Su richiesta, disponibili in acciaio inox
Under request, stainless steel available

¹⁾ Per filettatura a sinistra aggiungere il suffisso "L" (esempio: B-BSL.. - A-ASL..)
The shank of ball joint housing may be left-hand thread, for left-hand thread suffix "L" is added (example: B-BSL.. - A-ASL..)

²⁾ Disponibili su richiesta Available under request

Lavorazione normale : trattamento di zincatura FeZn7 Uni 4721 - a richiesta superficie grezza oliata
Surface : zinc-plating FeZn7 Uni 4721 - raw oiled surface available under request

³⁾ Piani di serraggio - Clamping plains